



EXPANSION CHANNEL (PNEUMATIC)

MULTIPLEX ACCESSORY

Description

Introducing our innovative Industrial Laundry Expansion Channel, designed to integrate seamlessly with our **Multiplex 1 Pro** or **Multiplex 2 Pro** dosing units.

Pneumatic Valves: The expansion channel is equipped with state-of-the-art pneumatic valves, providing reliable and precise control over the flow of water and detergents. This ensures optimum performance and efficient resource utilization in your laundry operations.

Configuration: Different options with 1, 2 or 4 products provide flexible solutions tailored to the different requirements of each laundry.

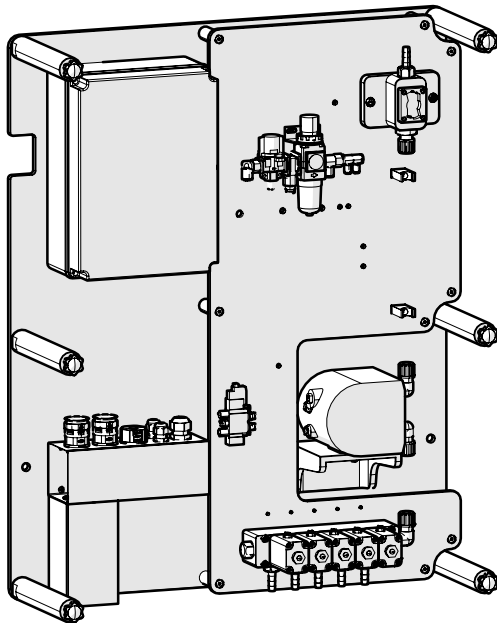

Technical Specifications

		Value
CONFIGURATION	Number of products	1
		2
		4
ELECTRIC PARAMETERS	Voltage	24 VDC
	Power	120W
AIR	Working pressure	58 PSI
	Air intake	3/8" barbed connector
	Average consumption	4.9 cubic feet per minute
	Air entrainment	Optional
	Condensation filter	Integrated
PANELS	Material	PVC

Technical Specifications

		Value
PUMPS	Number	1 pump per channel. Main channel: Pneumatic double diaphragm pump
	Flow rate (with water)	180 fl oz per minute
	Body	PVDF
	Membranes	PTFE
	Non-return valves	PVDF/FFKM
PRODUCT/WATER VALVES	Voltage	24 VDC
	Air tube	1/8"
	Body	PVDF
	Closure piston	PTFE
	O-rings	FKM
FLOW METERS	Standard measuring principle	Paddles + Hall effect sensor
	Signal	24 VDC PNP
	Body	PP
	Paddles	PVDF
	O-rings	FKM
	Alternative	*Oval gear not included. Supplied on request. Recommended with chemicals 180cP or higher.
CALIBRATION	Mode	Via distributor
	Measuring vase	Not included * recommended
WATER	Pressure in dynamic range	Min 22 PSI - Max 44 PSI Regulator recommended
	Flow range	Min 68 fl oz/min (Approx) Max 338 fl oz/min (Approx)
	Inlet connection	3/8" barbed connector
	Maximum temperature	< 86° F
	Required hardness	8 - 8.5 gpg (grains per gallon)
	Booster tank	Not included. Supplied on request. Recommended.

Details

Part Code	Description	Width	Height	Depth
A500CHP01B5	MULTIPLEX - PNEUMATIC EXPANSION CHANNEL C1 5,0L	25"	35"	10"
A500CHP02B5	MULTIPLEX - PNEUMATIC EXPANSION CHANNEL C2 5,0L	25"	35"	10"
A500CHP04B5	MULTIPLEX - PNEUMATIC EXPANSION CHANNEL C4 5,0L	25"	35"	10"

T (+1) 913-956-4909 E sales@brightwell-inc.com W brightwell-inc.com/

Brightwell Dispensers Inc. 9858 Britton Street, Lenexa, KS, 66219

All information in this data sheet is correct at the time of printing and is subject to change without notice.

Diagram

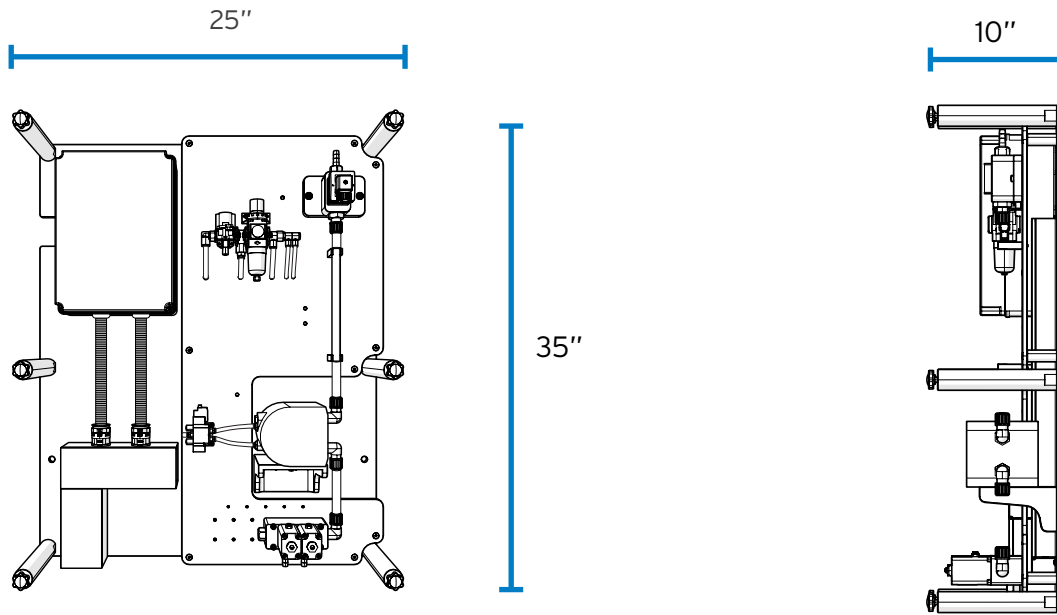

Dimensions

Width	25"
Height	35"
Depth	10"

Weight

Unit	42 (approx)
------	-------------

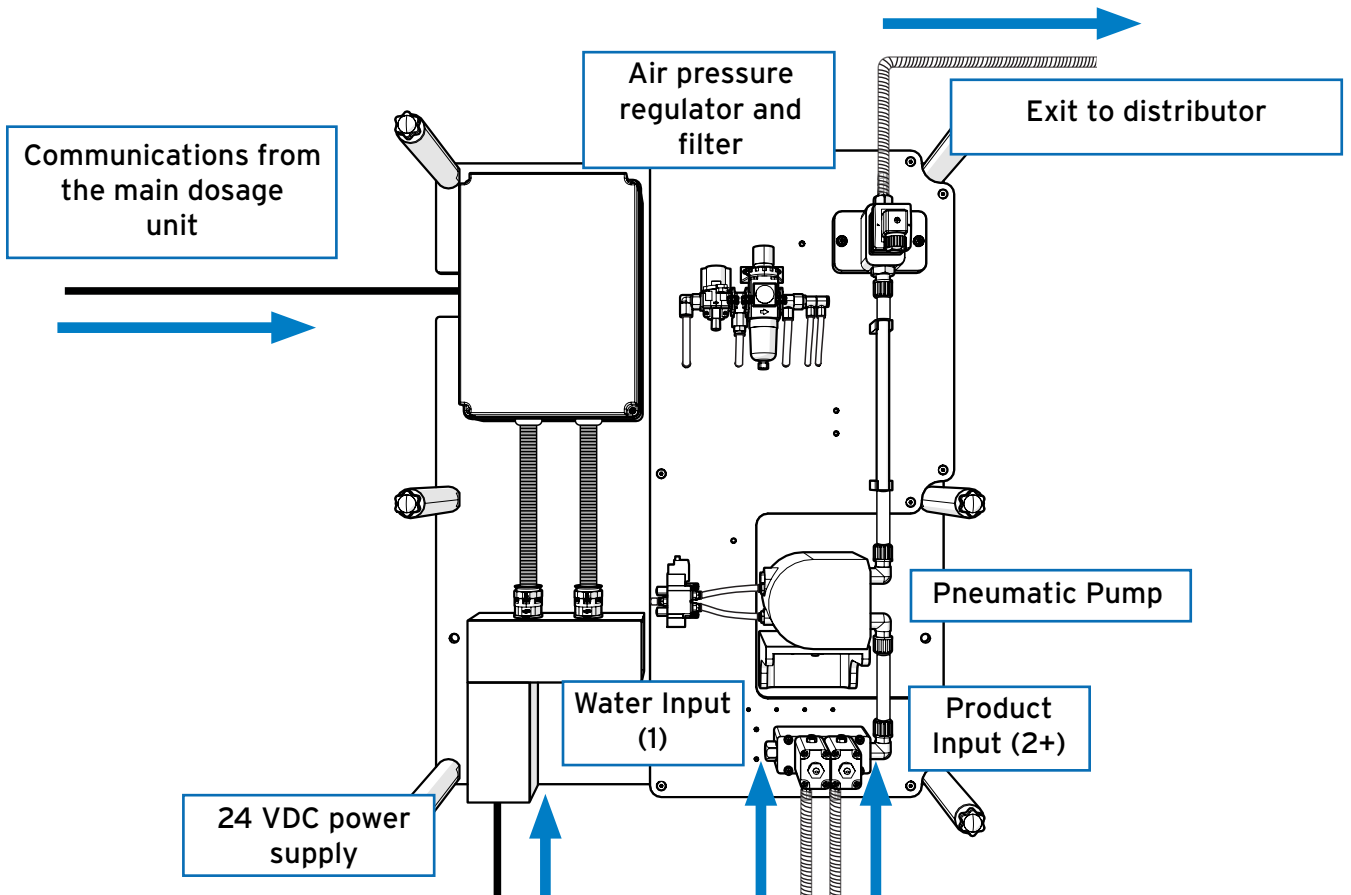

T (+1) 913-956-4909 E sales@brightwell-inc.com W brightwell-inc.com/

Brightwell Dispensers Inc. 9858 Britton Street, Lenexa, KS, 66219

All information in this data sheet is correct at the time of printing and is subject to change without notice.